

# ES Series

## ELECTRIC SCISSOR LIFTS



**Compact Size and Narrow Width For Ease of Access**



**CE Rated for Indoor/Outdoor Usage**



**Larger Platforms and Higher Capacities**

**1930ES**  
**2030ES**  
**2630ES**  
**2646ES**  
**3246ES**

**[www.jlg.com](http://www.jlg.com)**



# Get the Power To Do More with the New ES Series

Never before has a series of electric scissor lifts delivered this much power and versatility for both indoor and outdoor applications. All JLG ES Series electric scissor lift models feature a super efficient electric drive system providing industry leading duty cycles and noticeably quieter operations. An improved control station provides convenient one-handed operation, while carefully designed integration of major components into single assemblies helps reduce service needs and operating costs. Plus, when coupled with one of our exclusive Workstation in the Sky™ accessories, the ES Series can provide you with a powerful advantage on any job.



# ES Series



▲ **Higher Productivity**  
Compact and highly manoeuvrable, the narrow ES Series models provide the features needed by electricians, plumbers and facilities maintenance personnel.

▼ **Larger Platforms**  
With large 1.12 m x 2.50 m (3 ft. 8 in. x 8 ft. 2.5 in.) main platforms and 1.27 m (4 ft. 2 in.) extensions, the wider ES Series models deliver the deck space and capacity needed to handle multiple personnel and long length material.



The ES Series offers the most popular machine sizes, performance features and capabilities demanded by users and provides powerful productivity at an economical price.

# Efficient design, quiet operation

With modern styling, integration of major components into single assemblies, newly designed platforms, extensions and handrails, the ES Series of scissor lifts sets the industry standard for aesthetics, performance and cost of ownership.

## Longer battery life

The efficient ES Series electric drive enables more work cycles than any electric scissor lift on the market.



## Lower noise levels

The ES Series electric drive helps ensure quieter operation for more sound sensitive areas and applications such as office buildings, shopping malls, museums and schools.

## Integrated component design reduces operating costs

Integrated lift cylinder, valve, pump, motor and reservoir require only two hoses and four fittings, confining leak concerns to a single area.

Integrated motor, gearbox, spindle and brake facilitate service and troubleshooting while providing optimum power and performance.



## Workstation in the Sky™ Accessories Available

### Panel Rack

A JLG exclusive, the Panel Rack accessory provides storage of panels at the base of the machine to move with the machine and the capabilities to elevate up to 91 kg (200 lbs.) based on model.

### Pipe Rack Accessory

JLG's exclusive Pipe Rack Accessory is designed to secure pipes close to where they are needed. The pipe rack is mounted to the top platform rail and can hold up to 91 kg (200 lbs.) of pipe based on model.



### Drywall Gate is Standard

The Drywall Gate features a lock-in-place entry gate that allows for loading and unloading of 1.22 m x 3.66 m (4 ft. x 12 ft.) drywall sheets or other larger cargo.



### QuikWelder™ Package

This on-board welder eliminates the need to move bulky tanks, welding units and lead cables from project to project. With 200 amps of power you can weld light to heavy gauge steel - up to 1.27 cm (1/2 in.) and 1.9 cm (3/4 in.) aluminium.

Certain options and accessories are not available on all models, and other restrictions or conditions may apply. Please consult your local JLG representative.

### Fold-Down Handrails

Four models have standard fold-down handrails for access through low doorways. The Model 2030ES features a particularly compact design as the fold-down handrails reduce overall height to a mere 1.81 m. (5 ft 11.5 in.).



### One-Handed Operation

Proportional drive and lift controls provide smoother operation while the control placement allows for more operator comfort.

### Skid-Resistant Deck

Built from non-corrosive, high quality aluminium, the new JLG deck features non-skid strips for less slip and more grip for the operator.



### Fits Through Narrow Aisles and Doorways

With three narrow 0.76 m (30 in.) chassis models to choose from, operators enjoy an unprecedented amount of clearance through doorways and down tight aisles.

### Improved Mobility

Front wheel drive and front wheel steering offer tight turning circles for superior traction and manoeuvrability. And, with 0.14 m (5.5 in.)\* of ground clearance, the ES Series travels easier over doorway thresholds and allows drive-on loading for trailers and roll-back trucks.

\*9 cm (3.5 in.) on 0.76m (30 in.) wide models



### Longer Battery Life and Faster Charge Time

Measurably longer duty cycles are complemented by a quick charge system to keep your JLG ES scissor lifts on the job.



## ES Narrow Models

- More narrow models with platform heights from 6 m to 8 m (19 ft. to 26 ft.).
- More clearance through doorways and aisles with 0.76 m (30 in.) wide chassis
- More manoeuvrability with a tight turning radius
- More convenience with easier to use fold-down rails
- More flexibility and productivity with available accessories

## ES Wide Models

- More platform capacity up to 450 kg (1,000 lbs.)
- More reach with platform heights to 9.68 m (32 ft.)
- More workspace with wider decks and platform extensions
- More productivity with pipe racks, panel carriers and other accessories

# ES Series Specifications

Model 1930ES      Model 2030ES      Model 2630ES      Model 2646ES      Model 3246ES

## Dimensional Data\*

<b>A. Platform Height – Elevated</b>	5.72 m (18 ft. 9 in.)	6.10 m (20 ft.)	7.75 m (25 ft. 5 in.)	7.92 m (26 ft.)	9.68 m (31 ft. 9 in.)
<b>B. Platform Height – Lowered</b>	0.86 m (2 ft. 10 in.)	1.10 m (3 ft. 7.5 in.)	1.23 m (4 ft. 0.5 in.)	1.26 m (4 ft. 1.5 in.)	1.26 m (4 ft. 1.5 in.)
<b>C. Platform Railing Height</b>	1.10 m (3 ft. 7.5 in.)	1.10 m (3 ft. 7.5 in.)	1.10 m (3 ft. 7.5 in.)	1.10 m (3 ft. 7.5 in.)	1.10 m (3 ft. 7.5 in.)
<b>Overall Height</b>	1.98 m (6 ft. 5 in.)	2.20 m (7 ft. 3 in.)	2.20 m (7 ft. 3 in.)	2.33 m (7 ft. 8 in.)	2.33 m (7 ft. 8 in.)
<b>D. Stowed Height (Rails Folded)</b>	n/a	1.81 m (5 ft. 11.5 in.)	1.94 m (6 ft. 4.5 in.)	1.94 m (6 ft. 4.5 in.)	1.94 m (6 ft. 4.5 in.)
<b>E. Platform Dimensions</b>	0.76 m x 1.87 m (2 ft. 6 in. x 6 ft. 1.5 in.)	0.76 m x 2.30 m (2 ft. 6 in. x 7 ft. 6.5 in.)	0.76 m x 2.30 m (2 ft. 6 in. x 7 ft. 6.5 in.)	1.12 m x 2.50 m (3 ft. 8 in. x 8 ft. 2.5 in.)	1.12 m x 2.50 m (3 ft. 8 in. x 8 ft. 2.5 in.)
<b>F. Platform Extension</b>	0.90 m (2 ft. 11.5 in.)	0.90 m (2 ft. 11.5 in.)	0.90 m (2 ft. 11.5 in.)	1.27 m (4 ft. 2 in.)	1.27 m (4 ft. 2 in.)
<b>G. Overall Machine Width</b>	0.76 m (30 in.)	0.76 m (30 in.)	0.76 m (30 in.)	1.17 m (46 in.)	1.17 m (46 in.)
<b>H. Overall Machine Length</b>	1.87 m (6 ft. 1.5 in.)	2.30 m (7 ft. 6.5 in.)	2.30 m (7 ft. 6.5 in.)	2.50 m (8 ft. 2.5 in.)	2.50 m (8 ft. 2.5 in.)
<b>I. Wheelbase</b>	1.60 m (5 ft. 3 in.)	1.88 m (6 ft. 2 in.)	1.88 m (6 ft. 2 in.)	2.09 m (6 ft. 10.5 in.)	2.09 m (6 ft. 10.5 in.)
<b>J. Ground Clearance</b>	0.09 m (3.5 in.)	0.09 m (3.5 in.)	0.09 m (3.5 in.)	0.14 m (5.5 in.)	0.14 m (5.5 in.)
<b>Tyre Size, (Non-Marking Solid)</b>	0.31 m x 0.10 m (12.5 in. x 4 in.)	0.40 m x 0.12 m (16 in. x 5 in.)	0.40 m x 0.12 m (16 in. x 5 in.)	0.40 m x 0.12 m (16 in. x 5 in.)	0.40 m x 0.12 m (16 in. x 5 in.)

## Performance Data

<b>Max. Platform Capacity</b>	230 kg (500 lbs.)	360 kg (800 lbs.)	230 kg (500 lbs.)	450 kg (1,000 lbs.)	320 kg (700 lbs.)
<b>– Capacity On Deck Extension</b>	120 kg (250 lbs.)	120 kg (250 lbs.)	120 kg (250 lbs.)	120 kg (250 lbs.)	120 kg (250 lbs.)
<b>Lift/Lower Time</b>	22/28 seconds	30/30 seconds	40/40 seconds	40/40 seconds	50/50 seconds
<b>Maximum Drive Height</b>	5.72 m (18 ft. 9 in.)	6.10 m (20 ft.)	7.75 m (25 ft. 5 in.)	7.92 m (26 ft.)	9.68 m (31 ft. 9 in.)
<b>Drive Speed, Lowered</b>	4.8 km/h (3.0 mph)	4.4 km/h (2.75 mph)	4.4 km/h (2.75 mph)	4.0 km/h (2.5 mph)	4.0 km/h (2.5 mph)
<b>Drive Speed, Elevated</b>	0.8 km/h (0.5 mph)	0.8 km/h (0.5 mph)	0.8 km/h (0.5 mph)	0.8 km/h (0.5 mph)	0.8 km/h (0.5 mph)
<b>Gradeability</b>	25%	25%	25%	25%	25%
<b>Turning Radius (Inside)</b>	0	0	0	0	0
<b>Turning Radius (Outside)</b>	1.75 m (5 ft. 9 in.)	2.06 m (6 ft. 9 in.)	2.06 m (6 ft. 9 in.)	2.41 m (7 ft. 11 in.)	2.41 m (7 ft. 11 in.)

## Power System/Chassis

<b>Batteries</b>	4 x 6V, 220 amp-hr	4 x 6V, 220 amp-hr	4 x 6V, 220 amp-hr <sup>†</sup>	4 x 6V, 220 amp-hr <sup>†</sup>	4 x 6V, 220 amp-hr <sup>†</sup>
<b>Charger</b>	20 Amp Automatic (120V/240V–50/60HZ)	20 Amp Automatic (120V/240V–50/60HZ)	20 Amp Automatic (120V/240V–50/60HZ)	20 Amp Automatic (120V/240V–50/60HZ)	20 Amp Automatic (120V/240V–50/60HZ)
<b>Pump</b>	Fixed Clearance Gear	Fixed Clearance Gear	Fixed Clearance Gear	Pressure Balanced Gear	Pressure Balanced Gear
<b>Hydraulic Reservoir</b>	3.6 L (0.95 gal.)	4.73 L (1.25 gal.)	4.73 L (1.25 gal.)	7.1 L (1.9 gal.)	7.1 L (1.9 gal.)
<b>Brakes (On Drive Wheels)</b>	Electric, Auto Friction	Electric, Auto Friction	Electric, Auto Friction	Electric, Auto Friction	Electric, Auto Friction
<b>Gross Vehicle Weight</b>	1,565 kg (3,450 lbs.)	2,020 kg (4,450 lbs.)	2,155 kg (4,750 lbs.)	2,550 kg (5,620 lbs.)	2,725 kg (6,000 lbs.)
<b>Rail Type</b>	Fixed	Fold Down	Fold Down	Fold Down	Fold Down
<b>Drive</b>	6 kW (8 hp)	6 kW (8 hp)	6 kW (8 hp)	6 kW (8 hp)	6 kW (8 hp)

\*Certain weights and dimensions may vary due to options and to compliance with country standards.

<sup>†</sup> Optional 4x6V, 245 amp-hr

### Standard Features

0.90 m roll-out deck extension<sup>1</sup>, 1.27 m roll-out deck extension<sup>2</sup>, Removable platform console box, Lanyard attach points, Proportional drive speed control with thumb steer, Proportional lift/lower speed control, Joystick enable for drive and lift, 4 x 6V 220 A/hr deep cycle batteries, Automatic positive traction, Programmable "Personality" settings, On-board self-diagnostic testing, Slide-out battery/electrical compartment doors, 20 amp automatic SCR battery charger, Dual front wheel drive, Dual wheel brakes, Pothole protection system, AC cable to platform, Battery condition indicator, Hour meter, Fold down handrails<sup>3</sup>, Self-closing gate, Drywall gate, 450kg capacity<sup>4</sup>, Lubrication free scissor arm bushings, Scissor maintenance prop, Manual descent pull cable, Horn,

Non-marking solid tyres, Load Sensing System, Variable slope alarm and light, Tilt indicator, Tie down lugs, Fork lift pockets.

### Available Options

Platform work-lights, 245 Amp-hour batteries in lieu of 220 Amp-hour batteries<sup>3</sup>, Lifting lugs, Travel alarm, All Motion Alarm, Descent alarm, Flashing amber beacon Alarm package<sup>5</sup>

<sup>1</sup> Available on Models 1930ES, 2030ES and 2630ES only.

<sup>2</sup> Available on Models 2646ES and 3246ES only.

<sup>3</sup> Not available on Model 1930ES

<sup>4</sup> Available on Model 2646ES only

<sup>5</sup> Includes 2 degree slope alarm and light, amber beacon, and all motion alarm.

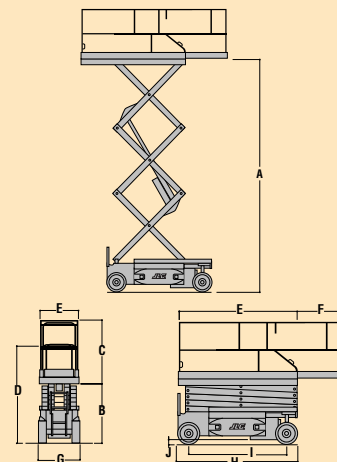

## The JLG "1 & 5" Warranty

JLG Industries, Inc. backs our products with our exclusive "1 & 5" Warranty. We provide coverage on all products for one (1) full year, and cover all specified major structural components for five (5) years. Due to continuous product improvements, we reserve the right to make specification and/or equipment changes without prior notification.

This machine meets or exceeds applicable ANSI A92.6-1999, CAN3-B354.2-M82 and OSHA regulations in 29 CFR 1910.67 and 29 CFR 1926.453 as originally manufactured for intended applications.

