



# Raising Profitability Faster than Ever!

You want a boom lift that is preferred by end users and has the lowest cost of ownership for improved profits. Your customers need to get into working position as quickly and efficiently as possible for optimum productivity on the job. That's why the JLG 400 Series telescopic boom lifts provide end-user benefits like the fastest lift and drive speeds, and the best gradeability and reach in their classes.

## 400 SERIES ADVANTAGES OVER COMPETITIVE PRODUCTS

- Reaches 2 to 3.5 Feet (0.61 to 1.07 m) Farther
- 90% Faster Boom Speed
- 100% More Platform Capacity Available
- 29% Faster Drive Speeds
- Field-Tested 45% Gradeability
- Four-Wheel Drive and Oscillating Axle Package

## Customer Preferred Controls

The 400 Series uses the same platform control arrangement as the entire JLG line of boom lifts to facilitate operator and technical training. The design reduces the number of buttons and switches used to position the platform, and controls are spaced for use with gloved hands.

## Semi-Track Option and Exclusive Floating Idler System

The Semi-Track option allows you to travel through mud, sand and snow. The floating idler system allows the drive wheels to remain in contact with the ground for improved traction on uneven surfaces. Plus, for added versatility, the Semi-Track option can be easily removed in the field and converted back to a wheeled unit by removing a few bolts.

## Greater Serviceability

JLG has streamlined preventive maintenance on the 400 Series by eliminating rear lube points and providing ease of access with an engine swing-out tray. This reduces the cost of routine maintenance work and reduces machine downtime.

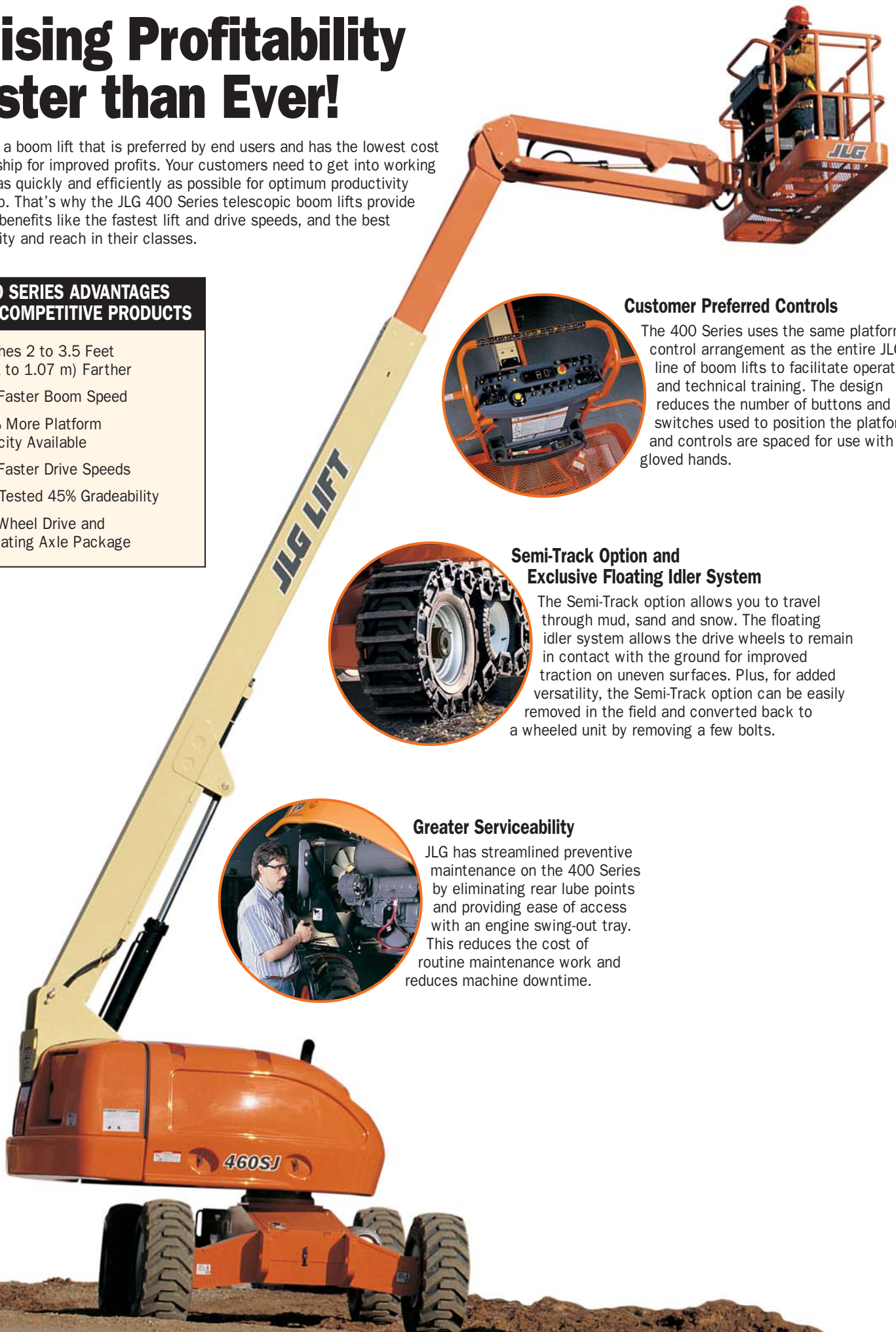



# Options to Create Your Workstation in the Sky® Product

Transform your Model 400S or 400SJ into a true Workstation in the Sky product with exclusive options and accessories from JLG®. Whether designed for a specific application like the SkyWelder® Package or to meet a variety of needs like the SkyPower® Package, JLG has many options available to increase your productivity and enhance your work environment.



## Operator Preferred Controls – Now with the Control ADE® System

The exclusive JLG Advanced Design Electronics (Control ADE) System helps optimize productivity while lowering your owning and operating costs.

- **Higher Productivity** – The Control ADE System provides smoother machine functions, increased fuel efficiency and reduced emissions.
- **Commonality of Components** – The Control ADE System is standard across all JLG engine powered boom lift models.
- **Enhanced Reliability** – The Control ADE System significantly reduces the number of wires and connections.
- **Improved Serviceability** – The Control ADE System self-test capability reduces troubleshooting time and identifies potential problems.
- **Enhanced Performance** – The Control ADE System allows function speeds and options to be customized to meet customer preferences.

### SkyPower Package



JLG delivers more power where you need it with the SkyPower Package. Machines outfitted with the SkyPower Package include a 7500W self-contained generator, plus a power cable and a ½ inch air line routed through the boom's power track to the platform. As an added benefit, the SkyPower Package is designed to work with various add-on accessories, including the SkyWelder Package.

### SkyWelder Package

Miller®\* welder is tucked into the SkyPower boom platform. Conserves space and provides stick and TIG capability. Eliminates potentially dangerous leads hanging over the rails and cost of a stand-alone welder and power supply. Wire feed capability and other convenient features are available.



### SkyGlazier® Package

The first and only factory-approved glass and panel tray. Utilize industry leading JLG capacity to get materials to the work site. Improves productivity and reduces operator fatigue, while protecting panels from damage.



### Nite Bright® Package

The JLG Nite Bright Package consists of six 40-watt lights—four chassis mounted lights and two platform mounted lights. The Nite Bright Package illuminates your work site plus the area around the chassis for increased visibility, and is perfect for nighttime work or any job with low lighting levels.



### SkyCutter® Package

Cut faster and cleaner with an on-board Miller plasma cutter. Eliminate the dangers of Oxygen/Acetylene tanks and hoses draped over the railings. Add SkyCutter Package (including a small air compressor) to any SkyPower unit for increased productivity.



### SkyAir® Package

Power air tools with the JLG on-board air compressor. Powered by SkyPower, SkyAir is a fully integrated solution that provides increased productivity by eliminating the dangers, costs and hassles of tethering to a separate ground-based compressor.



### Pipe Rack Accessory

The exclusive JLG Pipe Rack Accessory is designed to secure pipes close to where they are needed. The pipe rack is mounted to the top platform rail and can hold up to 180 lb (80 kg) of pipe.



Keep checking [www.jlg.com](http://www.jlg.com) for additional Workstation in the Sky accessories.

\*Miller is a trademark of Miller Electric®.



# JLG MODEL 400S/460SJ SERIES

# PERFORMANCE FEATURES

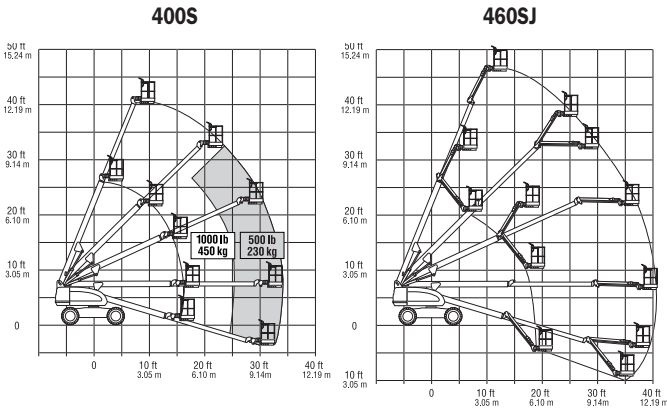

## REACH SPECIFICATIONS

Platform Height (400S)	40 ft 4 in. (12.3 m)
Platform Height (460SJ)	46 ft (14.02 m)
Horizontal Outreach (400S)	34 ft 1 in. (10.4 m)
Horizontal Outreach (460SJ)	40 ft 6 in. (12.34 m)
Swing	360 Degrees Continuous
Platform Capacity-Restricted (400S)	1,000 lb (450 kg)
Platform Capacity-Unrestricted	500 lb (227 kg)
Optional	750 lb (340 kg)
Platform Rotator	180 Degrees Hydraulic
Jib (Range of Articulation) (460SJ)	6 ft (1.83 m), 130 Degrees (+70, -60)
Lift/Lower Speed	29/22 seconds

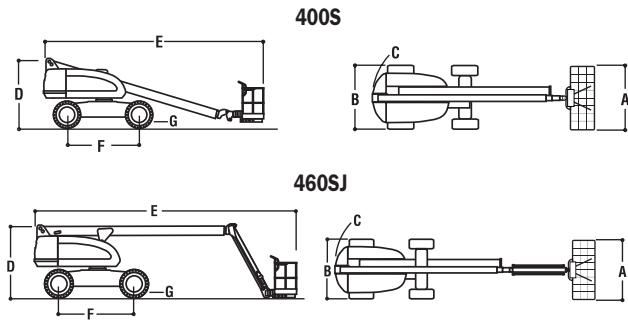

## DIMENSIONAL DATA

A. Platform Size	36 x 96 in. (0.91 x 2.44 m)
B. Overall Width	7 ft 6.5 in. (2.30 m)
C. Tailswing	2 ft 10 in. (86 cm)
D. Stowed Height	7 ft 10 in. (2.39 m)
E. Stowed Length (400S)	24 ft 9 in. (7.54 m)
E. Stowed Length (460SJ)	29 ft (8.84 m)
F. Wheelbase	7 ft 8 in. (2.34 m)
G. Ground Clearance (Standard Tires)	12.5 in. (32 cm)
(14 x 17.5 Tires)	13.5 in. (34 cm)
Gross Vehicle Weight* (400S)	12,525 lb (5,681 kg)
Gross Vehicle Weight* (460SJ)	15,855 lb (7,192 kg)
Max. Ground Bearing Pressure	58 psi (4.06 kg/cm <sup>2</sup> )

## CHASSIS

Drive Speed 2WD/4WD	4.5 mph (7.2 kph)
Gradeability 2WD	30%
Gradeability 4WD	45%
Turning Radius (Outside)	16 ft 5 in. (5.0 m)
Turning Radius (Inside)	6 ft 7 in. (2.00 m)
Tire Size/Type (Standard)	12 x 16.5 Pneumatic
(Optional)	14 x 17.5 Pneumatic

## POWER SOURCE

Dual Fuel Engine	Ford LRG-425 EFI, 82 hp (61.1 kW)
Diesel Engine	Deutz F3M1011, 48 hp (35.8 kW)
Diesel Engine	Caterpillar 3024C, 50 hp (37.2 kW)
Fuel Tank Capacity	26 gal. (98.5 L)
Hydraulic Reservoir	42 gal. (159 L)
Auxiliary Power	12V DC
Engine Noise Level (at max. rpm)	70 dBA @ 7 meters

\*Certain options or country standards will increase weight.

## Standard Features

- 6 ft (1.83 m) Articulating Jib (460SJ Only)
- Platform 36 x 96 in. (0.91 x 2.44 m) Side Entry
- Inward Self-Closing Swing Gate
- 180 Degree Hydraulic Platform Rotator
- Platform Console Machine Status Light Panel\*
- 110V-AC Receptacle in the Platform
- 5 Degree Tilt Alarm/Indicator Light
- 12V-DC Auxiliary Power
- Proportional Controls
- Lifting/Tie Down Lugs
- Hourmeter
- Control ADE® System
- Swing-Out Engine Tray
- Oscillating Axle
- 12 x 16.5 Rim Protector Lug Tread Tires
- Horn
- Operator Tool Tray
- All Motion Alarm

\* Provides indicator lights at platform control console for system distress, low fuel, 5 degree tilt light, and foot switch status.

## Options

- 750 lb (340 kg) Unrestricted Capacity with 1,000 lb (450 kg) Restricted Capacity<sup>1</sup>
- Platform Work Lights
- 36 x 72 in. (0.91 x 1.83 m) Platform
- ½ in. (1.3 cm) Air Line to Platform
- Soft Touch System
- Foam-Filled Tires
- 14 x 17.5 Lug Tread Tires
- High Flotation Sand/Turf Tire (4WD Only)
- 2500W Generator
- Tow Package<sup>2</sup>
- Flashing Amber Beacon
- 43.5 lb Propane Tank
- Cold Weather Start Kit<sup>3</sup>
- Hostile Environment Kit<sup>4</sup>
- Semi-Track<sup>5</sup>
- Light Package<sup>6</sup>

1. Not available on Model 460SJ.

2. Wheel Drive Only.

3. Includes engine block heater (Ford and CAT) or glow plugs assist (Deutz), battery heater, oil manifold heater and oil tank heater.

4. Includes boom wiper seals, cylinder bellow, turntable shield and console cover.

5. See Semi-Track brochure for details and machine requirements.

6. Includes head and tail lights and platform working lights.

## Accessories

**SkyPower Package** – Includes 7500W generator, power cable to platform, and ½ in. air line to platform.

**SkyWelder Package** – Includes SkyPower Package, 250-Amp Miller welder in the platform, leads, clamp and stinger.

**SkyCutter Package** – Includes SkyPower and Miller Plasma Cutter mounted in platform.

**SkyGlazier Package** – Includes glass/panel tray, protective foam padding and strap. (400S only)

**Nite Bright Package** – Includes six 40W lights (platform and chassis mounted).

**SkyAir Package** (requires SkyPower) – Includes 9 cfm onboard air compressor.

**SkyCutter and SkyAir Package** – Includes SkyPower and Miller Plasma Cutter mounted in platform and SkyAir.

**SkyWelder/SkyCutter/SkyAir Combination** (requires SkyPower)

**PipeRack** – Platform Mounted, 180 lb (80 kg) capacity.

## The JLG "1 & 5" Warranty

JLG Industries, Inc. backs our products with our exclusive "1 & 5" Warranty. We provide coverage on all products for one (1) full year, and cover all specified major structural components for five (5) full years. Due to continuous product improvements, we reserve the right to make specification and/or equipment changes without prior notification. This machine meets or exceeds applicable OSHA Regulations in 29 CFR 1910.67, 29 CFR 1926.453, ANSI A92.5-1992 and CSA standard CAN3-B354.4-M82 as originally manufactured for intended applications.

## JLG Industries, Inc.

1 JLG Drive, McConnellsburg, PA 17233-9533  
Telephone 717-485-5161 Toll-free in US 877-JLG-LIFT  
Fax 717-485-6417  
www.jlg.com

Printed in USA  
FORM NO.: SS-400S-1002-10M  
PART NO.: 3131026  
R050502



**The Power To Do More**